

CBD20/25-491 (UGD)

电动托盘搬运车 Electric Pallet Truck

产品性能特点:

- 驱动单元专利设计浮动机构。
- 高速快捷,行驶速度11公里/小时。
- 电子助力转向,轻便、静音。
- 交流驱动电机,无碳刷、免维护。
- 电起升,快速、高效,标配起升限位装置。
- 交流控制器,无级调速,动力强劲,多重自动保护。
- 弯道自动减速功能,更安全。
- 半包围驾驶舱,更关心您的安全。
- 独特的节能升降机构-导轨升降机构,电池不起升,更节能。
- 选配手柄高度可调。
- 锂电款采用磷酸铁锂电池,充电快、效率高。
- 蓄电池侧拉设计,更换便捷、高效。

Characteristics:

- Drive unit floating bodies with patent design.
- High running speed, driving speed is 11Km/h.
- Electronic power steering, light and low noise.
- AC driving motor without carbon brush and free maintenance.
- Electric lifting, rapid, efficient, electricity limit switch is STD.
- AC controller, stepless, strong power, multiple automatic protection.
- Curve automatic deceleration function, safer.
- Surrounded by half a cockpit, care for your safety.
- Unique energy-saving lifting mechanism - guide rail lifting mechanism, battery not lifting, more energy-saving.
- Optional handle with adjustable height.
- The LFP model lithium batteries are fast charging and efficient.
- Side-way battery, easy to replace.



CBD20/25-491 (UGD)

制造商和技术参数 Manufacturer's Data and Design Characteristics				
特性 Features				
1.01	型号	Model	kg	CBD20/25-491 (UGD)
1.02	操作类型	Operating type	mm	乘驾式 Ride-on
1.03	额定载重	Load capacity	mm	2000/2500
1.04	载荷中心距	Load center		600
1.05	轴距	Wheel base		1530
车轮 Wheels				
2.01	轮子类型	Wheels type		聚氨酯 PU
2.02	驱动轮/平衡轮/承重轮数量	Wheel quantity/Driving wheel/Balance wheel/Bearing wheel		1/2/4
2.03	驱动轮尺寸	Driving wheel size	mm	Φ248X75
2.04	承载轮尺寸	Bearing wheel size	mm	Φ84×80
2.05	平衡轮尺寸	Balance wheel size	mm	Φ115×55
尺寸 Dimension				
3.01	货叉最低离地高度	Min.fork lowered height	mm	85
3.02	货叉最大起升高度	Max.fork lifting height	mm	205
3.03	最大起升行程	Max.lifting height	mm	120
3.04	货叉外侧间距	Outside width between forks	mm	550/685
3.05	货叉内侧间距	Inside width between forks	mm	210/345
3.06	货叉长度	Fork length	mm	1150/1200
3.07	货叉宽度	Forkwidth	mm	170
3.08	货叉厚度	Fork thickness	mm	55
3.09	整车全长	Overall length	mm	2385/2435
3.10	车体宽度	Overall width	mm	812
3.11	整车高度(含手柄)	Overall height(With handle)	mm	1238
3.12	最小转弯半径	Min.Turning radius	mm	2210/2260
3.13	最小直角堆垛通道宽度(托盘800×2400,2400沿货叉放置)	Min.Aisle width for pallets 800×2400	mm	2850/2900
3.14	最小直角堆垛通道宽度(托盘1000×2400,2400沿货叉放置)	Min.Aisle width for pallets 1000×2400	mm	2943/2993
性能 Performance				
4.01	最大行驶速度,满载/空载	Travelling speed,laden/unladen	km/h	10/11
4.02	最大起升速度,满载/空载	Lifting speed,laden/unladen	mm/s	30/35
4.03	最大下降速度,满载/空载	Lowering speed,laden/unladen	mm/s	40/35
4.04	爬坡度,满载/空载	Gradeability,laden/unladen	%	10/15
4.05	制动类型	Service brake type		电磁制动 Electromagnetic
电气配置 Electrical configuration				
5.01	驱动电机额定功率S2 60分钟	Traction motor rating at S2 60min	kW	AC 3
5.02	起升电机额定功率S3 15%	Lift motor rating at S3 15%	kW	DC 2.2
5.03	电池	Battery		铅酸电池 Lead-acid battery 锂电 Lithium battery (Optional)
5.04	蓄电池电压/标称容量	Battery voltage / capacity	V/Ah	24/270 24/200
5.05	充电器规格	Charger specification	V/A	24/50 24/100
重量 Weight				
6.01	蓄电池重量(±5%)	Battery weight(±5%)	kg	247 105
6.02	自重(包含蓄电池)	Service weight with battery	kg	865 723
其他 Others				
7.01	噪音等级	Sound level	dB(A)	≤69
7.02	转向类型	Steering type		电转向 Electronic
7.03	驱动控制类型	Drive control type		交流控制 AC
7.04	控制器	Controller		前托 QXEPEND

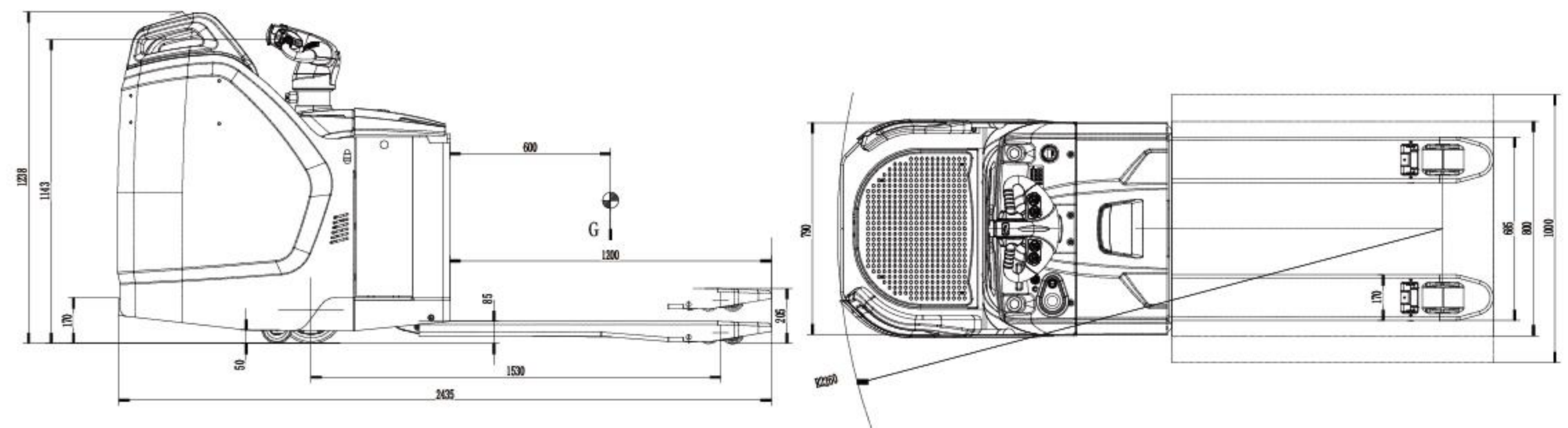

安徽合力股份有限公司
ANHUI HELI CO., LTD.
地址 / 中国 合肥方兴大道668号
Add / No.668, FangXing Road, Hefei, China
邮编 (Post Code) / 230000

客服热线 (Customer Service Hotline) / 4001-600761
服务电话 (Service Tel) / +86-551-63689000, 63648005

* 本公司保留更改产品设计和规格的权利,恕不另行通知。
* Our products are subject to improvements and changes without notice.