

HELI

CTD16-960/360 Straddle Electric Stacker

Load Curve

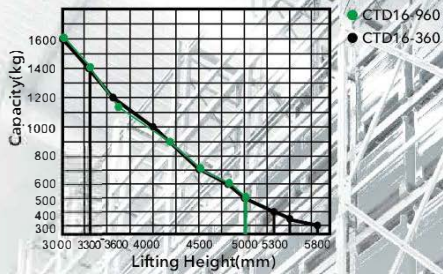

Configuration and performance

- Electronic power steering system, light and low noise.
- Two-way magnetic valve; three drop speed mode.
- Drive unit floating bodies with patent design.
- AC Driving system, No carbon brush, maintenance free.
- Electromagnetic, regenerative braking system.
- Automatic lifting limit, proximity switch, long life.

Safety

- Curve automatic deceleration devices, more safe.
- Vehicle decelerates automatically at higher position.
- Stepless speed control system, safe and quiet.
- Controller with Multiple automatic protection.
- Emergency reversing device/Emergency brake switch.
- High position automatic reduction device

Option

- Lithium battery

Economical straddle typed stacker

Steering automatic deceleration

AC | EPS | Down mode at 3 speeds

Truck automatically decelerates while at higher lifting position

Type	Lift height (mm)	Mast type	Outside width between legs (mm)	Inside width between legs (mm)
CTD16-960	3700/3900/4200/4500/4700/5000	Full Free 3-Stage	1170/1320/1470/1650/970/1120/1270/1450	
CTD16-360	5300/5500/5800	Full Free 3-Stage		

CTD16-960/360

Feature		CTD16	CTD16
Model		960	360
Configuration No.			
Type		Straddle	Straddle
Mast type		Full free 3-Stage	Full free 3-Stage
Load capacity	kg	1600	1600
Load center	mm	600	600
Wheel base	mm	1375	1375
Operating type		Walkie/Stand On	
Wheels			
Wheels type		PU	PU
Wheel quantity (Driving wheel/Balance wheel/Bearing wheel)		1/2/4	1/2/4
Dimension			
Standard lift height	mm	3700/3900/4200/4500/4700/5000	5300/5500/5800
Lowered fork height	mm	55	85
Fork size(length/width/thickness)	mm	1070/100/40	1070/100/40
Overall length	mm	2073/2493	2073/2493
Overall width	mm	1470	1470
Max.extend height	mm	4200/4450/4700/5000/5250/5500	5800/6000/6300
Mast lowered height	mm	1800/1900/1985/2085/2135/2235	2520/2590/2690
Min Turning radius	mm	1630/2040	1630/2040
Min.Aisle width for pallets 800×1200	mm	2230/2625	2230/2625
Min.Aisle width for pallets 1000×1200	mm	2260/2650	2260/2650
Min.ground clearance	mm	50	30
Performance			
Travel speed,laden/unladen	km/h	6/6	6/6
Lift speed,laden/unladen	mm/s	130/180	130/180
Lowering speed,laden/unladen	mm/s	100/200	100/200
Gradeability,laden/unladen	%	6/8	6/8
Electrical configuration			
Drive motor/Lift motor/Steering motor	kW	AC1.5/DC3/DC0.15	
Brake		Electromagnetic/Regenerative	
Weight			
		Lead-acid battery	Lithium battery (Optional)
Battery voltage	V	24	24
Battery capacity	Ah	280	200
Controller		ZAPI	ZAPI
Battery weight	kg	235	235
Service weight with battery	kg	1577	1454
		Lead-acid battery	Lithium battery (Optional)
		24	24
		280	200
		ZAPI	ZAPI
		235	235
		1657	1536

* Details of specifications and equipment are based on information available at time of printing and may change without notice.

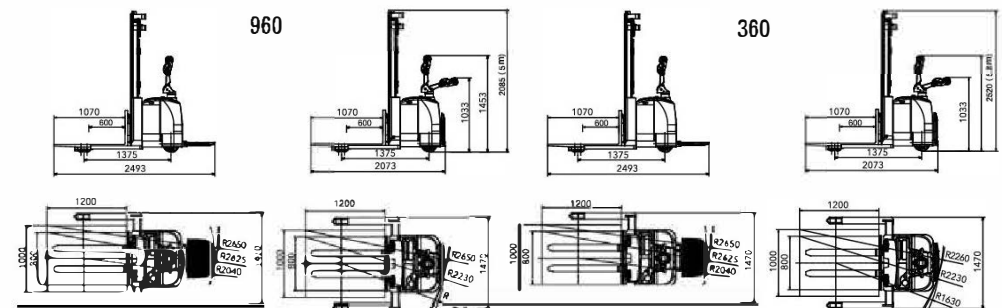

ANHUI HELI CO., LTD.

ADD: NO 668 Fangxing Street, Economical Development Zone, Hefei, P.R. China
 TEL: (86 551)63639068 (America) 63639258 (Europe) 63639358 (Asia)
 63662105 (Africa & Middle East) 63639530 (Key Accounts division)
 63662105 (Wheel loader)
 FAX: (86 551)63639966
 WEBSITE: <http://www.heliforklift.net>
 Email: heli@helichina.net

AUTHORIZED DEALER