

Manufacturer's Data and Design Characteristics

Characteristics					
1.01	Manufacturer		HELI		
1.02	Model		CBD16	CBD20	
1.03	Configuration number		C2LiH	C2LiH	
1.04	Type of operation		Pedestrian propelled	Pedestrian propelled	
1.05	Rated capacity	Q	kg	1600	2000
1.06	Load center distance	c	mm	600	600
1.07	Lift height	h3		122	122
1.08	Front overhang	x	mm	970	970
1.09	Wheelbase	y	mm	1255	1255
Tyres					
2.01	Tyre type			Polyurethane	Polyurethane
2.02	Tyre size, driving wheels	φ*w	mm	φ230*70	φ230*70
2.03	Tyre size, loading wheels	φ*w	mm	2*φ85*85	2*φ85*85
2.04	Tyre size, additional wheels	φ*w	mm	2*φ100*40	2*φ100*40
2.05	Wheels, number front/rear (x=driven wheels)			1x+2/2 or 4	1x+2/2 or 4
2.06	track width, loading side	b11	mm	500	500
Dimensions					
3.01	Overall length	L1	mm	1660	1660
3.02	Overall width	b1	mm	720	720
3.03	Fork dimension	s/e/l	mm	55*170*1150	55*170*1150
3.04	Width of forks	b5	mm	670	670
3.05	Lowered height	h13	mm	85	85
3.06	Min.Ground clearance	m2	mm	30	30
3.07	Height drawbar in driving position min./max	h14	mm	850/1271	850/1271
3.08	Aisle width with pallet 1000x1200 across forks	Ast	mm	2270	2270
3.09	Aisle width with pallet 800x1200 along forks	Ast	mm	2157	2157
3.10	Min.Turning radius	Wa	mm	1465	1465
Performance Data					
4.01	Travel speed (laden/unladen)		km/h	5.5/6	5.5/6
4.02	Lift speed (laden/unladen)		mm/s	40/50	40/50
4.03	Lowering speed (laden/unladen)		mm/s	50/40	50/40
4.04	Max.gradeability (laden/unladen)		%	10/20	10/20
4.05	Service brake type			Electromagnetic brake	Electromagnetic brake
Battery					
5.01	Battery voltage/rated capacity		V/Ah	24V/90Ah	24V/150Ah
5.02	Battery weight		kg	60	70
5.03	Battery box dimension (length x width x height)		mm	660×154×610	660×154×610
Motor and controller					
6.01	Driving motor powering (S2-60min)		kW	1.1	1.1
6.02	Lifting motor powering (S3-15%)		kW	2.2	2.2
6.03	Controller			ZAPI	ZAPI
Weight					
7.01	Total weight (with battery)		kg	375	385
Addition data					
8.01	Type of drive control			AC	AC
8.02	Sound pressure level at the driver's ear		dB(A)	≤69	≤69
8.03	Steering type			Manual steering	Manual steering

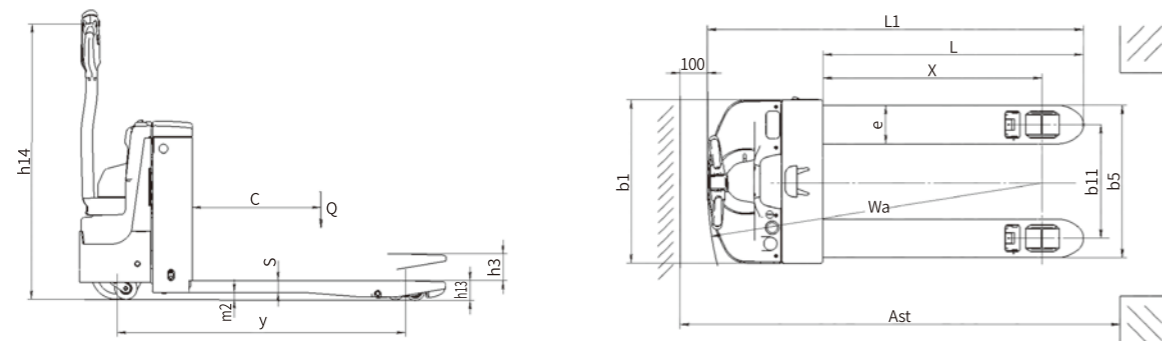

ANHUI HELI CO., LTD.

Add / No.668, FangXing Road, Hefei, China

Fax / +86-551-63639966

Tel / +86-551-63639068(America); 63639258(Europe);

63639358(Asia); 63662105(Africa & Middle East)



LinkedIn



YouTube



Facebook

CBD16/20

C2LiH



LI-ION 1.6-2 t

H Series Pedestrian Pallet Truck



1.6-2.0 t

CBD16/20-C2LiH

H Series Pedestrian Pallet Truck

Appearance

- H series pallet truck adopts professional appearance industrial design, the whole truck has smooth lines and novel appearance;
- Sturdy and durable, in line with the requirements of environmental protection.

High performance

- Large battery capacity, strong range capability
- Adopting AC traveling motor, excellent acceleration performance, good climbing performance;
- ZAPI controller, precise and smooth control, higher efficiency;
- Switch, connectors and other important parts adopt high-end brand products;
- The whole vehicle has been fully strengthened and verified, reliable and durable.

Comfort

- Integrated handle design, standard with smart handle, simple and comfortable operation;
- Side charging design makes charging more convenient;
- Optimized compact body structure and large rounded corner design are suitable for the vehicle to operate in narrow space, greatly improving the passability.

Reliability

- Standardly equipped with auxiliary wheels, making the whole vehicle with better stability;
- Non-contact proximity switches are adopted for long life and reliable operation;
- High-performance hydraulic power unit, low noise, smooth lifting and lowering;
- Reliable battery fixing, the battery box cover is supported by soft material to reduce the vibration and noise generated during the operation of the vehicle.

Safety

- Electromagnetic brake unlocking device is reserved to ensure that the vehicle can be moved for maintenance in case of failure;
- Emergency stop switch and emergency reverse device are equipped as standard to ensure the safety of use;
- The traveling brake adopts the double guarantee of electromagnetic brake and motor brake to ensure the traveling safety.

Maintenance

- The rear cover can be opened completely and the components can be seen at a glance, which makes the maintenance of the whole vehicle very convenient;
- All the rotating shafts are installed with lubricated bushings and oil nozzles for easy maintenance and long service life.



Multifunctional instrument:
Can display power, mode, use time fault code.



Built-in covering, more beautiful



Integrated handle design



Standard two-wheel mechanism

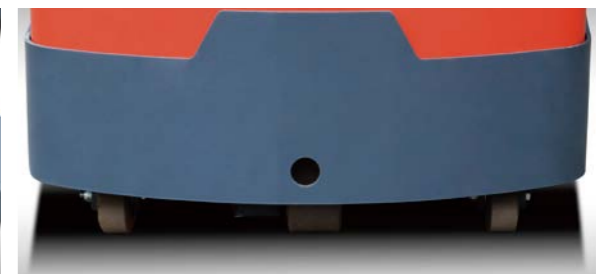

Standard auxiliary wheel, higher truck stability



Comprehensive protection, even in the lifting state, there is still cover protection



Centralized layout, more convenient operation